

Design of Knuckle Joint

- A knuckle joint is used to connect two rods which are under the action of tensile load, when small amount of flexibility or angular moment is necessary.
- The line of action of load is always axial.
- The knuckle joint consist of three major parts.
 - a) Single eye
 - b) Double eye
 - c) Knuckle pin

- The single eye is formed at the one end and double eye is formed at the other end of the rod.
- The single eye fit into fork or double eye, both the parts are connect by pin inserted through eye.
- The knuckle pin has a head at one end and collar and taper pin or split pin at other end.
- The ends of the rod are of octagonal forms for improving the gripping at the time of repairs.
- [Knuckle Joint Video](#)

- **Function of Split pin –**

It holds collar and prevent lifting or ejecting the knuckle pin from the joint.

Applications of knuckle Joint –

1. Tie rod of roof truss
2. Link of roller chain
3. Tension link in bridge structure
4. Tie rod joint of jib crane.

Knuckle joint

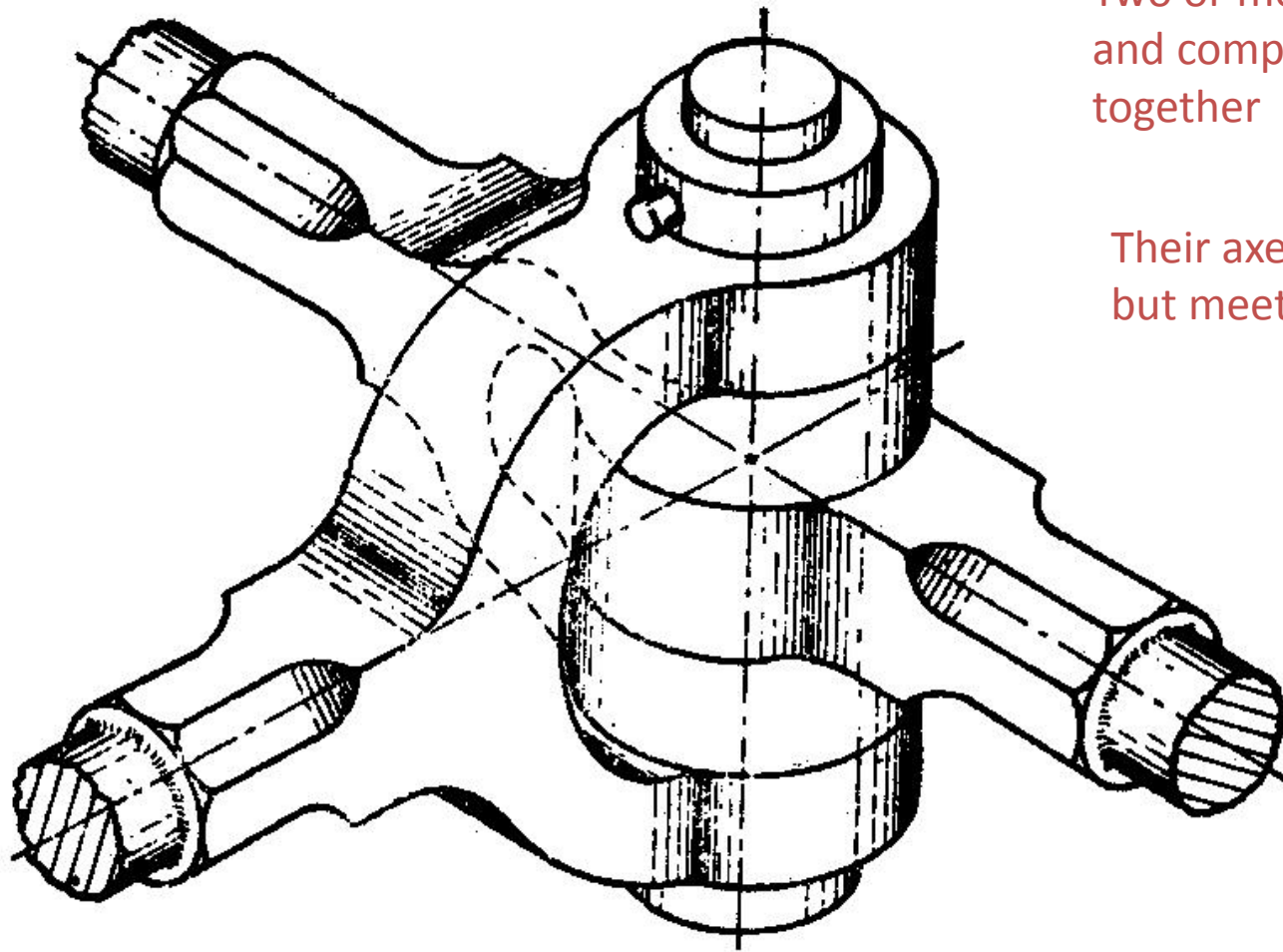

Two or more rods subjected to tensile and compressive forces are fastened together

Their axes are not in alignments but meet in a point

The joint allows a small angular moment of one rod relative to another

It can be easily connected and disconnected

Applications: Elevator chains, valve rods, etc

Knuckle joint

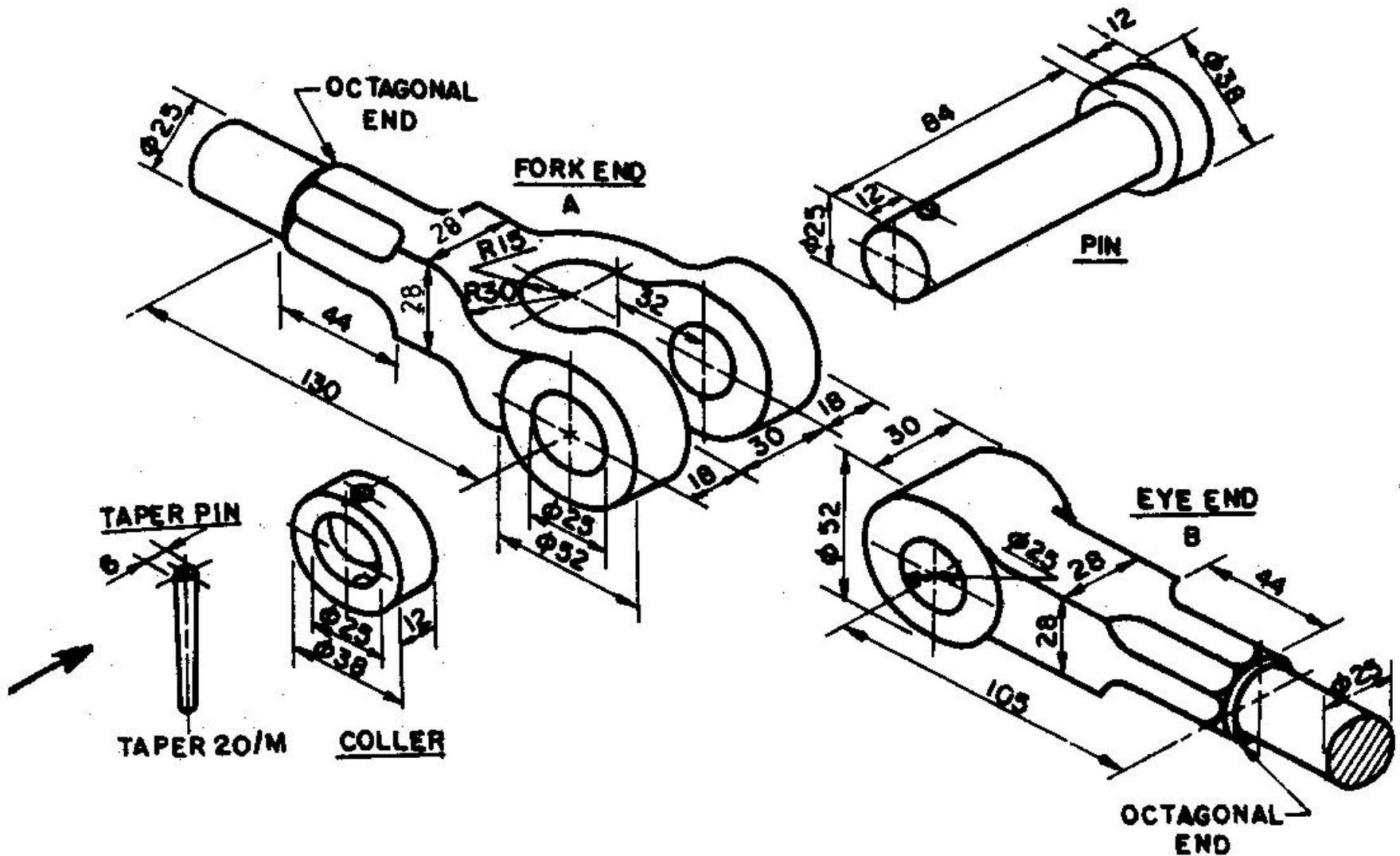

- Let P = tensile load acting on rod

d = diameter of rod

d_1 = diameter of pin

d_2 = outer diameter of eye.

d_3 = diameter of knuckle pin head & collar.

t = thickness of single eye.

t_1 = thickness of fork.

t_2 = thickness of pin head.

Empirical Relations

Diameter of pin = $d_1 = d$

Outer diameter of eye = $d_2 = 2d$

Diameter of knuckle pin head & collar = $d_3 = 1.5d$

Thickness of single eye = $t = 1.25d$

Thickness of fork = $t_1 = 1.75d$

Thickness of pin head $t_2 = 0.5d$

Design Procedure

1) Failure of rod in tension

$$\sigma_t = \frac{P}{\frac{\pi}{4} d^2} \text{ --- (1)}$$

From this equation d is obtained

2) Failure of knuckle pin

a) Failure of knuckle in double shear.

$$\tau = \frac{P}{2 \times \frac{\pi}{4} d_1^2} \text{ --- (2)}$$

From this equation diameter of knuckle pin (d_1) is obtained

This assume that, there is no slack or clearance, but in actual practice pin is loose in fork to permit angular moment of one with respect to other. So it is subjected to bending moment in addition to shear

b) Considering bending failure of knuckle pin

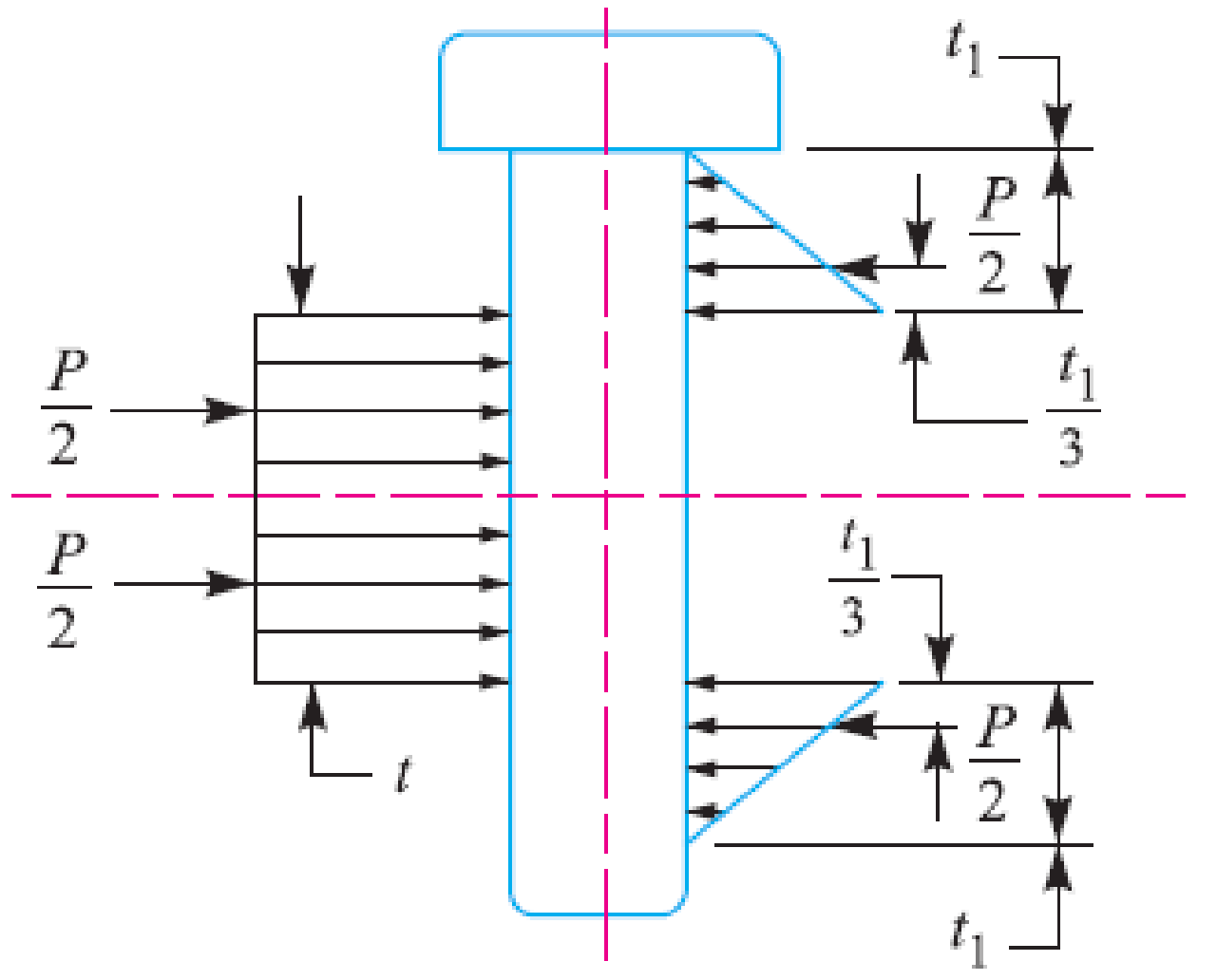

$$\begin{aligned}
 M &= \frac{P}{2} \left(\frac{t_1}{3} + \frac{t}{2} \right) - \frac{P}{2} \times \frac{t}{4} \\
 &= \frac{P}{2} \left(\frac{t_1}{3} + \frac{t}{2} - \frac{t}{4} \right) \\
 &= \frac{P}{2} \left(\frac{t_1}{3} + \frac{t}{4} \right)
 \end{aligned}$$

$$\text{Section modulus} = Z = \frac{\pi}{32} d_1^3$$

$$\therefore \sigma_t = \frac{M}{Z} = \frac{\frac{P}{2} \left(\frac{t_1}{3} + \frac{t}{4} \right)}{\frac{\pi}{32} d_1^3} \text{----- (3)}$$

From this equation (d_1) is obtained

3) Failure of single eye end in tension

- Single eye end may tear of due to tension.

$$\sigma_t = \frac{P}{(d_2 - d_1) \times t} \text{ --- (4)}$$

From this equation (σ_t) for the single eye end may be checked.

4) Failure of Single eye end in shearing

- Considering the shear failure of single eye end.

$$\tau = \frac{P}{(d_2 - d_1) \times t} \text{ --- (5)}$$

From this equation shear stress (τ) for single eye end may be checked.

5) Failure of single eye end in crushing

- Considering the crushing failure of single eye end.

$$\sigma_{cr} = \frac{P}{d_1 \times t} \quad \text{--- (6)}$$

From this equation crushing stress (σ_{cr}) for the single eye or pin may be checked.

6) Failure of forked end in tension

- Considering the tensile failure of double eye of forked end.

$$\sigma_t = \frac{P}{(d_2 - d_1) \times 2t_1} \text{ --- (7)}$$

From this equation tensile stress (σ_t) for the forked end may be checked.

7) Failure of forked end in shear

- Considering the shear failure of forked end.

$$\tau = \frac{P}{(d_2 - d_1) \times 2t_1} \text{ --- (8)}$$

From this equation shear stress (τ) for the forked end may be checked.

8) Failure of forked in crushing

- Considering the crushing failure of forked end.

$$\sigma_{cr} = \frac{P}{d_1 \times 2t_1} \text{ --- (9)}$$

From this equation, the crushing stress in the forked may be checked.

1. First of all, find the diameter of the rod by considering the failure of the rod in tension. We know that tensile load acting on the rod,

$$P = \frac{\pi}{4} \times d^2 \times \sigma_t$$

where

d = Diameter of the rod, and

σ_t = Permissible tensile stress for the material of the rod.

2. After determining the diameter of the rod, the diameter of pin (d_1) may be determined by considering the failure of the pin in shear. We know that load,

$$P = 2 \times \frac{\pi}{4} (d_1)^2 \tau$$

A little consideration will show that the value of d_1 as obtained by the above relation is less than the specified value (*i.e.* the diameter of rod). So fix the diameter of the pin equal to the diameter of the rod.

3. Other dimensions of the joint are fixed by empirical relations as discussed in Art. 12.13.

4. The induced stresses are obtained by substituting the empirical dimensions in the relations as discussed in Art. 12.14.

In case the induced stress is more than the allowable stress, then the corresponding dimension may be increased.

Sr. No.	Knuckle Joint	Cotter Joint
1	It takes only tensile load	It takes tensile as well as compressive load.
2	It allows angular movement between rods	It can not allow angular movement
3	It is subjected to bearing failure.	It is not subjected to bearing failure.
4	No taper or clearance provided on knuckle pin.	Taper or clearance will be provide on cotter.
5	Ex – tie bar, links od bicycle chain, joint for rail shifting mechanism	Ex- cotter foundation bolt, joining of two rods with a pipe, joining piston rod with c/s head.

Problems

Example 12.7. *Design a knuckle joint to transmit 150 kN. The design stresses may be taken as 75 MPa in tension, 60 MPa in shear and 150 MPa in compression.*

UNIT 2

DESIGN OF SLEEVE AND COTTER JOINT

Introduction

- This joint is used to connect two round rods or bar.
- In this a sleeve is used over the two rod and then two cotters are inserted in the holes provided for them in the sleeve and rod.
- The taper sides of the two cotters should be face each other as shown in fig.
- The clearance is so adjusted that when the cotter are driven in the two rod come closer to each other and thus make the joint tight.

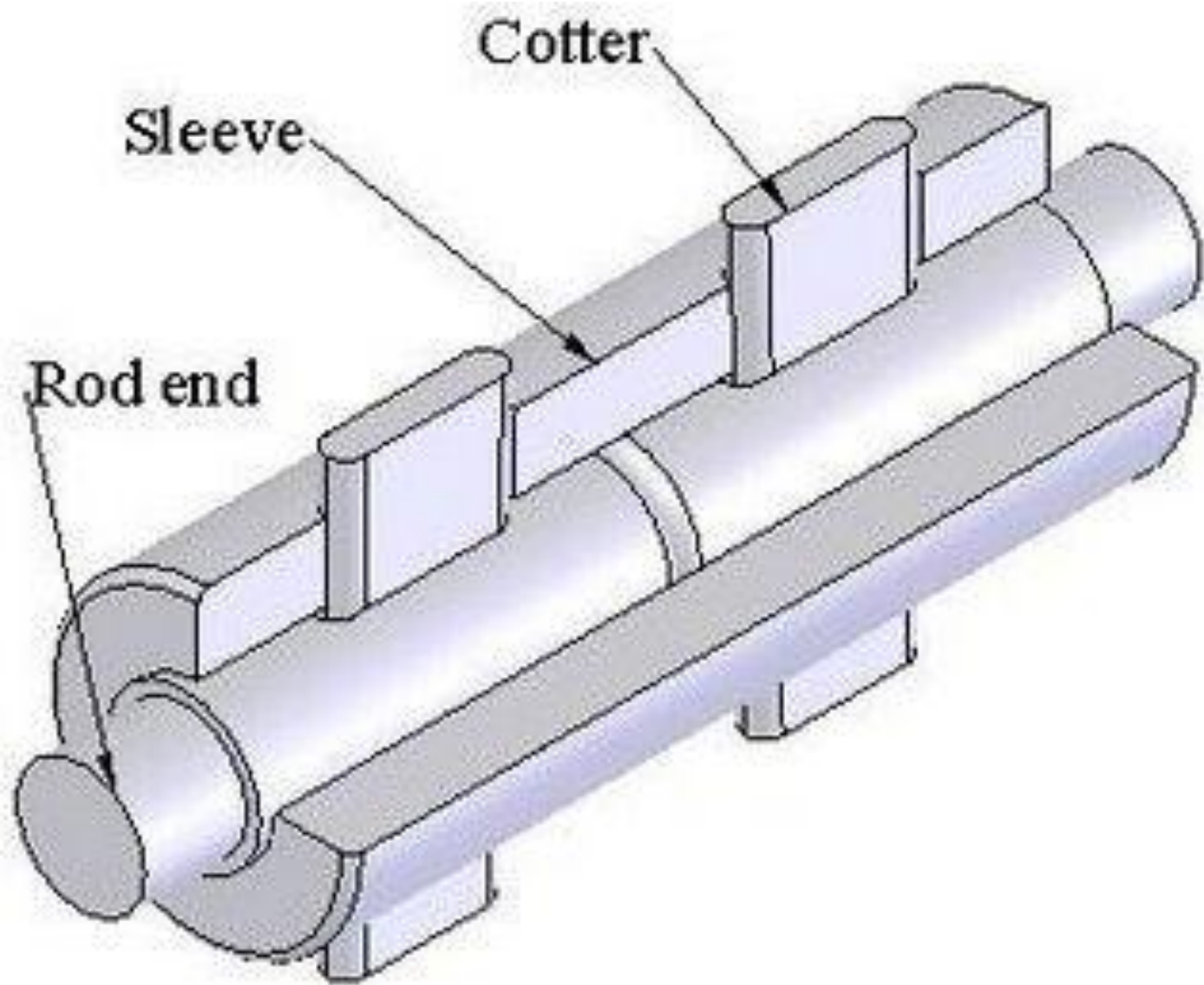

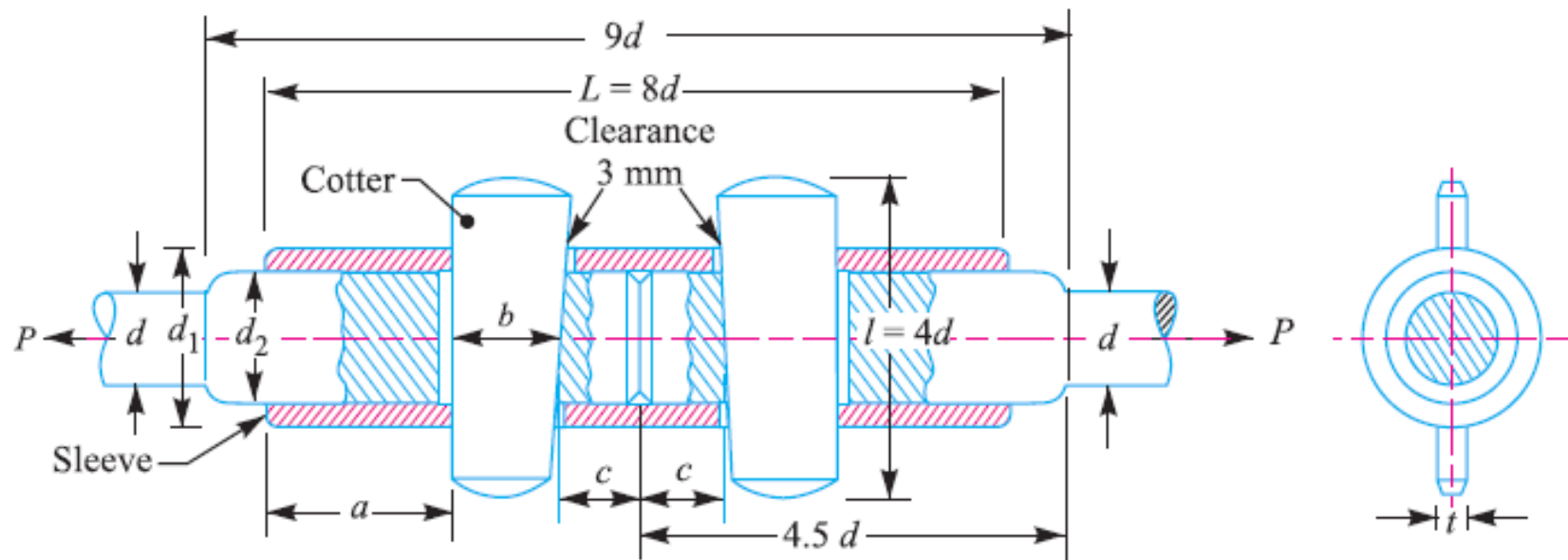

Let d = diameter of rod

d_1 = outside diameter of sleeve = $2.5d$

d_2 = diameter of enlarged end of rod = $1.25d$

t = thickness of cotter = $\frac{d_2}{4}$ or $0.31d$

l = length of cotter = $4d$

b = width of cotter

a = distance of the rod end from beginning to the cotter hole

(Inside the sleeve) = $1.25d$

C = distance of the rod end from its end to cotter hole

P = Load carried by the rod

1. Diameter (d)

- Consider failure of rod in tension due to applied force.

$$\sigma_t = \frac{P}{\frac{\pi}{4} d^2} \text{ --- (1)}$$

From this equation d may be obtained

2. Diameter of enlarge end of rod (d_2)

- Consider failure of rod in tension at weakest section.

$$\sigma_t = \frac{P}{\left(\frac{\pi}{4} d_2^2 - d_2 t\right)} \text{ --- --- --- (2)}$$

From this equation find d_2 taking $t = \frac{d_2}{4}$

3. Failure of cotter in crushing

- Considering the crushing failure of cotter.

$$\sigma_{cr} = \frac{P}{d_2 t} \text{ --- (3)}$$

From this equation check σ_{cr}

$$\sigma_{cr} \leq \sigma_{cr}(\text{Given})$$

4. Failure of sleeve across the slot in tension

$$\sigma_t = \frac{P}{\left\{ \frac{\pi}{4} (d_1^2 - d_2^2) - (d_1 - d_2) \times t \right\}} \quad \text{--- (4)}$$

From this equation outside diameter of sleeve (d_1) is obtained.

5. Width of Cotter

- Considering the double shear failure of cotter

$$\tau = \frac{P}{2bt} \text{ --- (5)}$$

From this equation width of cotter (b) is obtained

6. Find Distance 'a'

- Considering shear failure of enlarge end of rod.

$$\tau = \frac{P}{2ad_2} \text{ --- --- (6)}$$

From this equation 'a' is find out

7. Find distance 'C'

- Considering double shear failure of sleeve end (if cotter is stronger than sleeve).

$$\tau = \frac{P}{2(d_1 - d_2) \times C} \text{ --- --- --- (7)}$$

From above equation 'C' is obtained.

END OF DESIGN